

# Robolite 2

## Emergency Lighting

A simple vandal resistant design with a screw fixed opal diffuser.



## Dimensions

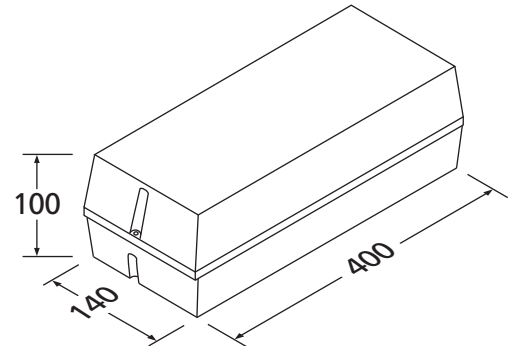

## Technical Specification

### Electrical & Operational

<b>Input voltage</b>	230 – 240v 50Hz
<b>Duration</b>	3 hours (maintained & non-maintained)
<b>Battery</b>	High temperature nickel cadmium
<b>Charger</b>	Constant current
<b>Charging monitor</b>	LED
<b>M operation</b>	Ballast maintained
<b>Recharge period</b>	24 hours
<b>Lamp</b>	8wT5
<b>Lamp o/p (lumens)</b>	400 (mains) 100 (maintained & non-maintained)
<b>Consumption (amps)</b>	0.17 (mains), 0.03 (non-maintained), 0.06 (maintained)

### Construction & Installation

<b>Cable entry</b>	20mm rear knockout, M20 thread at each end
<b>Construction</b>	Epoxy powder coated die cast aluminium base, moulded opal polycarbonate diffuser. Screw fixed metal geartray
<b>Environment</b>	0 – 25°C
<b>Ingress class</b>	IP65
<b>Weight (kg)</b>	1.2 (mains), 1.4 (non-maintained) 1.9 (maintained)
<b>Product standard/Approvals</b>	Designed & manufactured to meet the requirements of BS EN 60598.2.22

## To Order

### Product Order Codes

<b>EL-ROB8/3NM+</b>	8w Non-maintained Vandal Resistant Bulkhead
<b>EL-ROB8/3M+</b>	8w Maintained Vandal Resistant Bulkhead
<b>EL-ROB8/230+</b>	8w 230v Vandal Resistant Bulkhead

### Legend Codes

<b>EL-ROB+LEG</b>	Self Adhesive Legend for Robolite 2
-------------------	-------------------------------------

Please note that specifications may be subject to change.

For further information or technical assistance call or write to:

Senate Electrical  
Senate House, 6 - 16 Southgate Road, Potters Bar, Hertfordshire, EN6 5DS  
Telephone: 01707 640 000 Facsimile: 01707 640 000 Helpline on 01452 712459