

LOW VOLTAGE WIRE SYSTEM



HILINE

A low voltage lighting wire system to provide contemporary lighting to any scheme. High quality machined steel adjustable lamp holders take low voltage power for the Dichroic lamp from the twin suspension wires.

HILINE SYSTEM

| Part No. | Description | Code |
|----------|---------------|------|
| | Hiline System | 4669 |

Fittings

| | |
|---------|--------------------|
| HL50SPT | Hiline Spot |
| HL50SP2 | Pendant Spot 900mm |

Pendant Spot can be cut to length



SPECIFICATION

- High quality chrome plated fittings
- Requires GX5.3 cap 12V lamps
- 3mm clear insulated wire
- Versatile horizontal and vertical mounting
- Fully adjustable high quality spot fitting via intergrated handle

SUSPENSION WIRE

| Part No. | Description |
|----------|------------------------------|
| HL2X3M | 2x3m Suspension Wires (300W) |
| HL2X6M | 2x6m Suspension Wires (300W) |

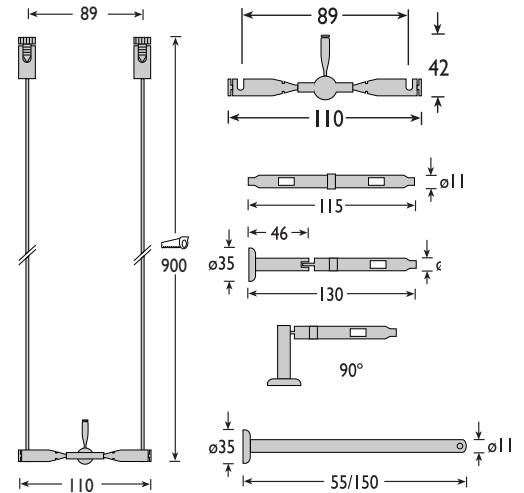
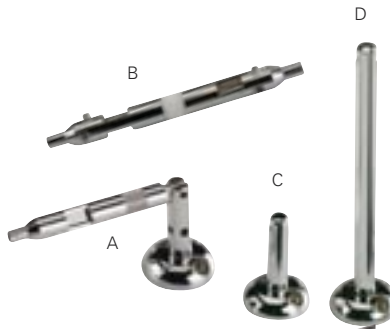

ACCESSORIES

| Part No. | Description | Fig. |
|----------|----------------------------|------|
| HL1TC | Tensioning Connector | A |
| HL2IC | Inline Isolating Connector | B |
| HL155SP | Support Pillar-55mm | C |
| HL150SP | Support Pillar-150mm | D |

Isolating connector used for extending runs of wire (extra transformer required)

240-12V SURFACE CONTROL PACK

| Part No. | Description | Code |
|-------------|-----------------------|------|
| HLVT200 ALM | 200VA 12V Transformer | 4296 |
| HLVT300 ALM | 300VA 12V Transformer | 4298 |

Aluminium finish as standard also available in
WHI = White
BLK = Black



SPECIFICATION

- Hiline wire wound transformers have thermal, overload and essential short circuit protection with automatic reset

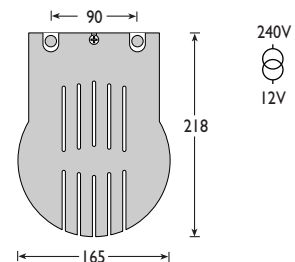
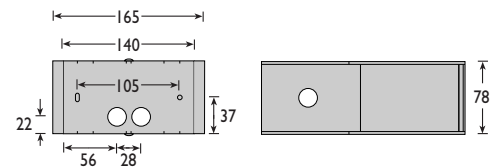

LAMP GUIDE

See pages 143-145 for a comprehensive lamp guide

