

SECTOR

Installation and User Instructions Unvented Electric Storage Water Heater Models: S10UNV, S15UNV.

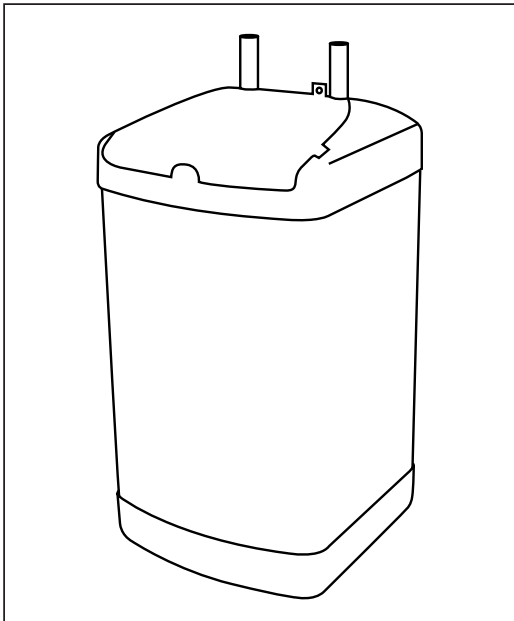

Please read and understand these instructions before starting work.
Please leave this leaflet with the user following installation

PACK CONTENTS

Heater, Pressure relief valve, Fixing screws and plugs,
Installation and user instructions.

WARNING

This water heater must only be installed by qualified persons.

Please read and understand these instructions prior to installing your Sector unvented water heater. Particular attention should be paid to the section headed **IMPORTANT INSTALLATION POINTS**. Following installation and commissioning the operation of the heater should be explained to the customer and these instructions left with them for future reference.

TECHNICAL SPECIFICATION

Electrical rating	2.0kW @ 230V ~
.....	2.2kW @ 240V ~
Capacities	10 or 15 litres
Weight (full)	10 litre - 15.9 kg
.....	15 litre - 23.1 kg
Rated pressure	6 bar (0.6 MPa)
Minimum recommended supply pressure	0.8 bar (0.08 MPa)
Pressure Relief Valve	6 bar (0.6 MPa)

1.0 IMPORTANT INSTALLATION POINTS

1.1 This unvented water heater **MUST** be fitted with the Pressure (Expansion) Relief Valve supplied. This **MUST** be fitted to the cold water supply near the heater.

FAILURE TO PROVIDE ADEQUATE PRESSURE RELIEF WILL INVALIDATE ANY GUARANTEE AND LEAD TO A DANGEROUS INSTALLATION

1.2 Expansion can take place within the cold water supply provided that both:

(a) Backflow in the main is not prevented by any stopvalve with loose jumper, check valve, pressure reducing valve or similar.

(b) Hot water expansion **does not** enter a branch to a cold water outlet (see Figure 1 for expansion pipe lengths).

N.B. Both of the above conditions must be met. Additionally, expansion within the cold water supply will not be possible if the static supply pressure exceeds 4.1 bar (60p.s.i.).

1.3 If any of the conditions in 1.2 cannot be met, expansion must be accommodated using an Expansion Vessel. To ensure that all expansion takes place in the vessel a Non Return Valve **must** also be fitted together with a Pressure (Expansion) Relief Valve (see Figure 2). Use Accessory Pack SPACK ALK05.

1.4 If the static supply pressure exceeds 4.1 bar (60p.s.i.) a Pressure Reducing Valve must be fitted to the cold main supply. If a Pressure Reducing Valve is used an Expansion Vessel must also be used. Use accessory pack SPACK ALK04 (see Figure 3).

1.5 Where specifications demand the fitting of a Temperature/Pressure Relief Valve, one can be fitted on site (see Figure 4). Use Accessory Pack SPACK ALK06. Note the fitting of SPACK ALK06 does not alter the requirements detailed in points 1.1 to 1.4.

WARNING:
IF WATER FLOWS FROM THE PRESSURE RELIEF VALVE OR
TEMPERATURE/PRESSURE RELIEF VALVE (IF FITTED) THE ELECTRICITY
SUPPLY MUST BE SWITCHED OFF IMMEDIATELY AND PROFESSIONAL
ADVICE SOUGHT.

FIGURE 1 : FOR INLET WATER PRESSURES UP TO 4.1 BAR (60 P.S.I.) - NO ADDITIONAL KITS USED.

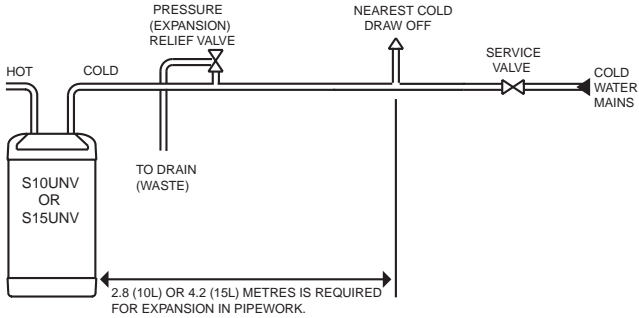

FIGURE 2 : FOR INLET WATER PRESSURES UP TO 4.1 BAR (60 P.S.I.)
 WHERE EXPANSION IN MAIN SUPPLY IS NOT POSSIBLE - USING KIT SPACK ALK05

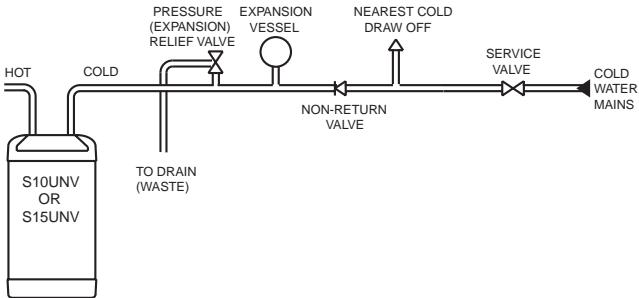
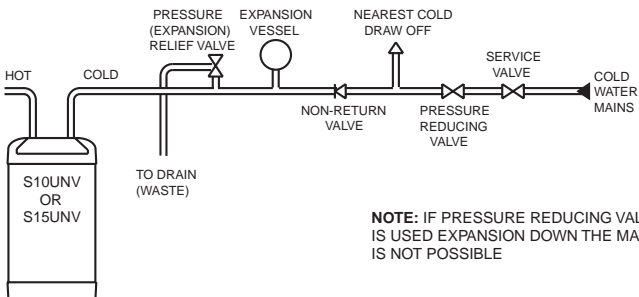
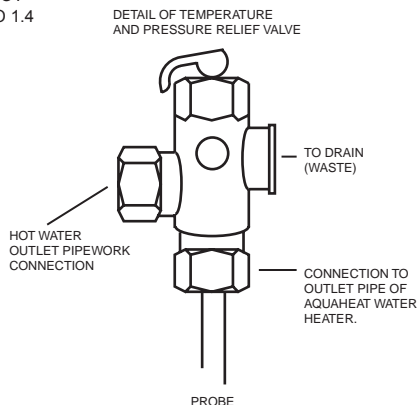
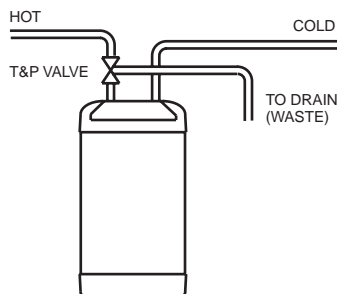

FIGURE 3 : FOR INLET WATER PRESSURES ABOVE 4.1 BAR (60 P.S.I.) - USING KIT SPACK ALK04



NOTE: IF PRESSURE REDUCING VALVE IS USED EXPANSION DOWN THE MAINS IS NOT POSSIBLE

FIGURE 4: TEMPERATURE AND PRESSURE RELIEF VALVE.
 □ NOTE: THE FITTING OF SPACK ALKO6 DOES NOT
 □ ALTER THE REQUIREMENTS OF POINTS 1.1 TO 1.4



2. INSTALLATION - GENERAL REQUIREMENTS

- 2.1 National Wiring rules may contain restrictions concerning the installation of these units in bathrooms.
- 2.2 The unit should be vertically wall mounted using the screws and plugs provided. Position the bottom two screws as shown in Figure 5 with heads 3mm from the wall. Hang the Heater and secure with the top screw.
 Alternatively it can be floor mounted on its base. The water connections must always be to the top of the unit.
- 2.3 Enough space should be left at the top above the unit for pipe connections and access to the Temperature/Pressure Relief Valve if fitted. Refer to Figure 5 and the Dimensions Table to determine a suitable position for the heater.
- 2.4 NOTE: Ensure that the wall can support the full weight of the unit (see technical specifications) and that there are no hidden services (electricity, gas, or water) below the surface of the wall.
- 2.5 DO NOT install where the unit may freeze.
- 2.6 Refer to the section IMPORTANT INSTALLATION POINTS to determine which valves and accessories are required. Plumb in the valves in the sequence shown in the relevant Diagrams (Figures 1 to 3).
- 2.7 Both inlet and outlet pipes are clearly labelled. The pipes are 15mm copper tube and are suitable for compression fittings.
 It is recommended that a WRAS listed isolating valve (not supplied) is fitted on the cold water supply to the heater. Several hot outlets can be served.
- 2.8 Do not use solder joints as this will damage the heater and may prevent servicing under warranty.
- 2.9 Plumbers Paste must not be used as it can impair the operation of the valves.

FIGURE 5: DIMENSIONS

DIMENSION	10 LITRE	15 LITRE
A	442mm	598mm
B	322mm	478mm
C	437mm	593mm
D	492mm	648mm
E	240mm	240mm
F	100mm	100mm
G	120mm	120mm
H	240mm	240mm
I	57mm	57mm

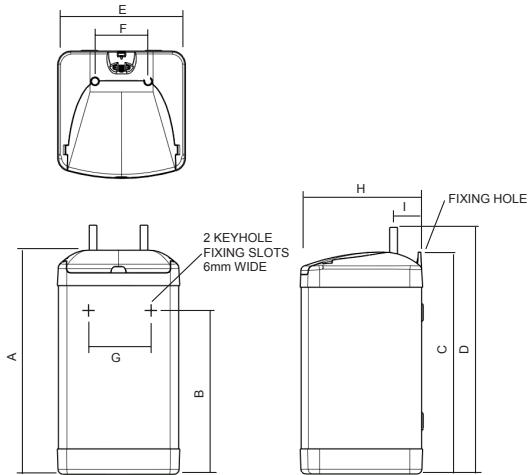

3. INSTALLATION - ELECTRICAL REQUIREMENTS

WARNING: This appliance must be earthed. It is suitable for a.c. supply only. Disconnect the electrical supply before removing the terminal cover.

Installation must be in accordance with the current I.E.E. Wiring Regulations.

3.1 The unit is supplied fitted with a 0.75m 3 core 1.5mm² flexible cable. The electricity supply should be fused 13 Amp and be via a double pole isolating switch with a contact separation of at least 3mm in both poles. Refer to the schematic wiring diagram, Figure 6, on the next page.

3.2 The wires are colour coded as follows:

Green and Yellow	EARTH	(\perp)
Brown	LIVE	(L)
Blue	NEUTRAL	(N)

FIGURE 6: WIRING DIAGRAM 'AC' ONLY.

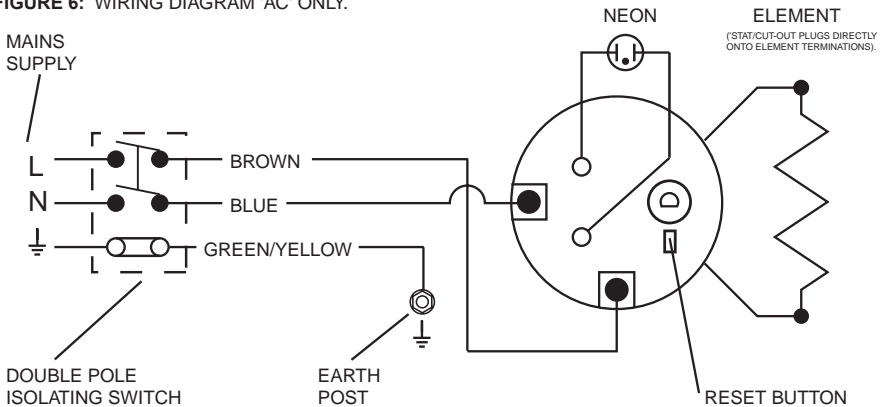

IMPORTANT: THE COMBINED THERMOSTAT/CUT-OUT MUST BE PUSHED FULLY HOME TO ENSURE CORRECT OPERATION OF THE CUT-OUT

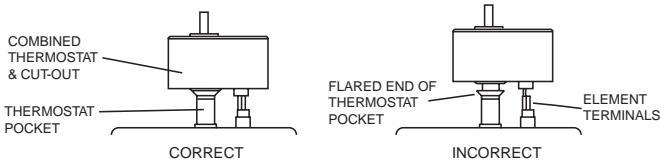

4.0 INSTALLATION - DISCHARGE PIPE REQUIREMENTS

- 4.1 The discharge outlet from the Pressure (expansion) Relief Valve and the Temperature/Pressure Relief Valve (if fitted) must be connected to a discharge pipe. It is recommended that a tundish (not supplied) be installed in the discharge pipe to give a visible indication that the valves are operating.
- 4.2 The discharge pipe must fall continuously from the valve outlets and be unobstructed.
- 4.3 The pipe from the valves to the tundish should be 15mm o/d minimum. From the tundish to the point of discharge the pipe should be 22mm o/d minimum and have a resistance to flow equivalent to 9 metres of straight pipe. Long discharge pipe runs should have an increased internal diameter.
- 4.4 The pipe material should be capable of conveying water/steam at 100°C.
- 4.5 The final discharge point should be in a safe, visible position.

5.0 COMMISSIONING

- 5.1 Do not switch on the electrical supply until the unit has been filled with water and checked for leaks.
- 5.2 Check that all installation, electrical and discharge pipe requirements have been met.

- 5.3 Check that all water and electrical connections are tight.
- 5.4 Open a hot water tap, turn on mains water supply to the heater.
- 5.5 Allow unit to fill and leave hot tap running for a short while to purge any air and flush out the pipework. Close the hot tap and check the system for leaks.
- 5.6 Manually test the operation of the Pressure (expansion) Relief Valve and, if fitted, the Temperature/Pressure Relief Valve. Ensure water flows freely from the valve(s) and through the discharge pipes.
- 5.7 Switch on the electrical supply.
- 5.8 The set temperature can be adjusted by rotating the shaft located on the Combined Thermostat and Thermal Cut-out, clockwise increase the temperature. Access to adjust the temperature is gained by removing the terminal cover.

6. REMOVAL AND FITTING OF TERMINAL COVER

- 6.1 To remove the terminal cover use a large flat bladed screwdriver to relieve the snaps located towards the front, at either side, of the cover. Gripping the cover at the front, pull upwards.
- 6.2 To fit the cover, locate the hinge at the back. Slide the snaps into place. Apply pressure to the front of the cover pushing back and down until it snaps securely in place.

7. MAINTENANCE - DESCALING

Little maintenance is required, however in hard water areas the unit will require periodic descaling to ensure efficient operation. To descale the unit:

- 7.1 Switch off and disconnect the electrical supply. Turn off the water supply to the unit.
- 7.2 Open a hot tap to relieve any system pressure. Disconnect the plumbing connections to the unit and remove the heater (note full weights of units). Empty unit through the outlet connection.
- 7.3 Remove the terminal cover as described in Section 6.
- 7.4 Disconnect the electrical terminations to the thermostat. Disconnect earth links to the earthing stud.
- 7.5 Remove the element plate assembly by unscrewing the five securing screws, tapped jacking points are provided. Remove any loose scale from the container. Carefully clean off any scale from the element and thermostat pocket. DO NOT clean scale from interior container walls.
- 7.6 Re-fit the element plate assembly using a new sealing gasket. Note the correct orientation of the element plate by reference to Figure 7 overleaf. Rewire the unit with reference to the Wiring Diagrams.
- 7.7 Re-commission the unit following the INSTALLATION and COMMISSIONING instructions.

FIGURE 7: CORRECT ORIENTATION OF ELEMENT PLATE (VIEWED FROM TOP OF UNIT).

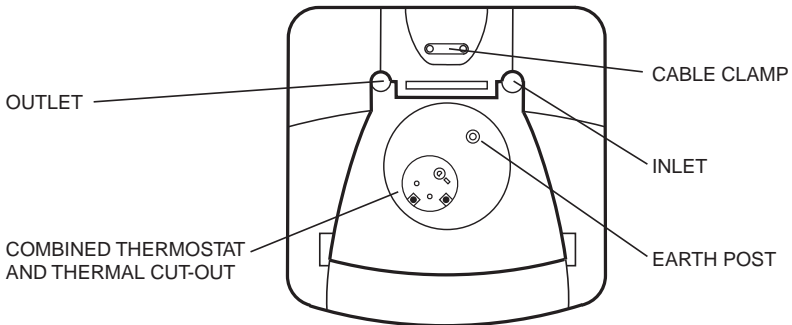

8. MAINTENANCE - SAFETY VALVES

The Pressure (expansion) Relief Valve and, if fitted, the Temperature/Pressure Relief Valve should be regularly checked. Manually operate the valves by either twisting the cap or lifting the lever. Ensure water flows freely from the valve(s) and through the discharge pipes. Ensure the valve(s) reseat correctly when released.

9. MAINTENANCE - EXPANSION VESSEL PRECHARGE PRESSURE

The Expansion Vessel, if fitted, should have a precharge pressure of 4.1 bar (60 p.s.i.). This can reduce over time and eventually require re-charging. To do this:

- 9.1 Turn off water supply to the unit; open a hot tap to relieve system pressure.
- 9.2 Remove dust cap from top of Expansion Vessel
- 9.3 Check pre-charge pressure using a tyre pressure gauge. If the pressure is lower than 4.1 bar (60 p.s.i.) it should be recharged using a tyre pump (Schraeder Valve type). DO NOT OVER CHARGE.
- 9.4 Re-check pressure and when correct replace dust cap.
- 9.5 Turn on mains water supply and close hot tap.

10. SPARE PARTS

The following comprehensive list of spare parts is available for your Sector water heater. Please refer to the Rating Label on the side of your heater before ordering to ensure the correct spare part is obtained.

DO NOT REPLACE WITH PARTS NOT RECOMMENDED BY MANUFACTURER - THIS WILL INVALIDATE YOUR GUARANTEE AND MAY RENDER THE INSTALLATION DANGEROUS.

DESCRIPTION	CODE NO.
Element plate assembly - 10 litre 2.2kW	95 606 940
Element plate assembly - 15 litre 2.2kW	95 606 941
Combined thermostat/thermal cut-out	95 612 687
Element plate gasket	95 611 708
Pressure (expansion) Relief Valve	95 607 986
Temperature/Pressure Relief Valve	95 607 854
Top cover moulding	95 614 272
Terminal cover	95 614 274

11. FAULT FINDING

Disconnect the electrical supply before removing the terminal cover. It is recommended that any service operations on this Sector heater are carried out by a qualified engineer.

FAULT	POSSIBLE CAUSES	ACTION
Water not heating	1. Electrical supply fault	1. Check electrical supply
	2. Thermal cut-out tripped	2. Check cut-out, if operated reset and check thermostat operation. If necessary replace thermostat/thermal cut-out (see Wiring Diagram)
	3. Thermostat fault	3. Check thermostat operation, replace if necessary
Discharge of water from Pressure Relief Valve (continuously)	Excessive mains water pressure	Fit Pressure Reducing Valve Pack SPACK ALK04 (see section 1.0)
Discharge of water from Pressure Relief Valve (intermittently)	1. Expansion in mains not possible.	1. Fit pack SPACK ALK05 (see section 1.0)
	2. Mains pressure exceeds 4.1 bar (60 p.s.i.)	2. Fit pack SPACK ALK04 (see section 1.0)
	3. Pressure Relief Valve Fault	3. Replace Pressure Relief Valve.
	4. Loss of pressure from Expansion Vessel	4. Check and if necessary, re-charge Expansion Vessel pre-charge pressure (see Section 9.0)
Discharge of water from Temperature/Pressure Relief Valve and or water/steam from Pressure Relief Valve	Thermostat and thermal cut-out fault	Replace thermostat and thermal cut-out
No water flow	1. Inlet valves incorrectly fitted	1. Check all valves are correctly installed in accordance with flow direction arrows
	2. Mains water supply not turned on	2. Check mains water supply is on
	3. Blockage in mains water supply	3. Check for obstructions. If pack SPACK ALK04 is fitted check strainer is not blocked.
"Milky" water	Oxygenated water	Water from a pressurised system releases oxygen bubbles when flowing. The milkiessness will disappear after a short time.

NOTE: Use only Sector approved spare parts. Replacement of any parts with components not recommended by Sector will invalidate the guarantee and may render the installation dangerous.

12. ACCESSORIES

The heater can be used to supply several hot water outlets via conventional taps. It is not recommended for supplying a shower. Individual site demands should be considered when choosing capacity and the number of outlets to be served.

A Thermostatic Blending Valve can be used in conjunction with this unit. Accessory Pack SPACK ALK03 is recommended. Follow the installation instructions supplied with the valve for connection to the system.

13. USER INSTRUCTIONS

13.1 This Sector unvented water heater stores water at the temperature set on the adjustable thermostat. This can be set to give temperatures in the range of 10 to 70° C. To avoid any risk of freezing when the heater is not in use for long periods during the winter months, do not switch off the electrical supply and set the thermostat to its minimum position. N.B. This will not protect other system pipework.

13.2 To ensure the heater continues to operate at its optimum performance it should be periodically maintained in accordance with the instructions given under the Sections headed MAINTENANCE.

13.3 IMPORTANT NOTES TO USER

Do not block or restrict the discharge from any safety valve fitted.

Do not tamper with any safety valve fitted.

If water discharges from any safety valve fitted, switch off the electrical supply to the unit immediately. Contact a qualified installer. Do not turn the electrical supply on again until the unit has been checked and approved by a qualified installer.

14. GUARANTEE

This product is guaranteed against faulty materials and manufacture for a period of 2 years from the date of purchase provided that:

1. The unit has been installed in accordance with the Installation and User Instructions and all relevant Codes of Practice and Regulations in force at the time of Installation, and that all necessary controls and safety valves have been fitted correctly.
2. Any valves and controls are of the Sector recommended type and specification.
3. The unit has not been modified or tampered with in any way, and has been regularly maintained as detailed in the Installation and User Instructions.
4. The unit has been used only for heating potable water.

The unit is not guaranteed against damage by frost, and the inner container with integral immersion heater is not guaranteed against excessive scale build-up.

This Guarantee in no way affects the statutory rights of the consumer.

The policy of Sector is one of continuous product development and, as such, we reserve the right to change specifications without notice.



Hurricane Way, Norwich, Norfolk, NR6 6EA.
For help with fitting and using your Sector water heater please call:
01603 420347 (fax 01603 420349).